

HelioJET



Central

CLEANING SYSTEMS™



The Latest in
High Pressure
Hot Water
Technology



How it Works

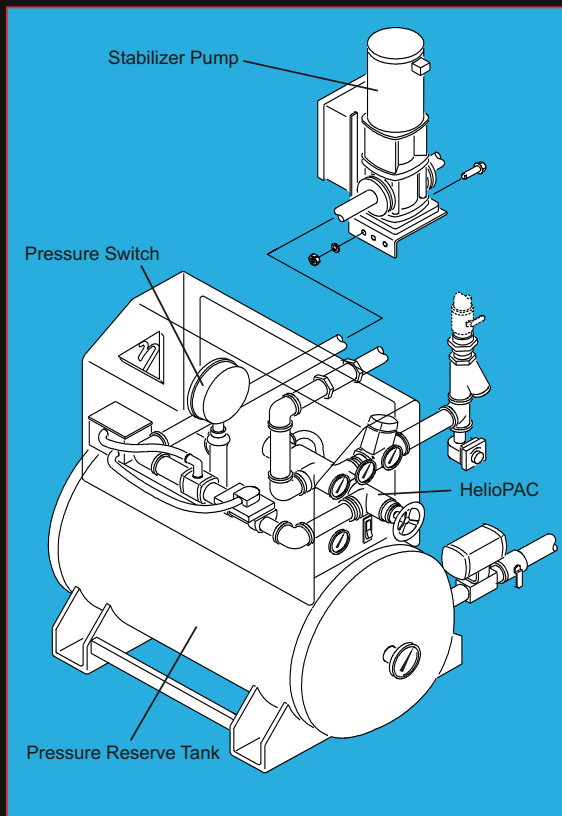
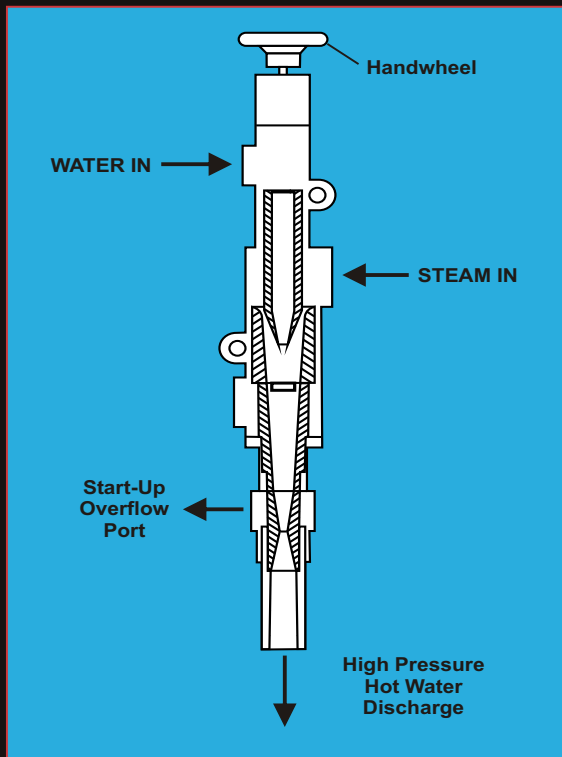

Sanitation at its Best!

Clean, sanitize, degrease, and disinfect like never before with the HeliJET[®] Central Cleaning System[™]. The Central Cleaning System combines your in-plant steam and cold water supplies and delivers high pressure hot water to multiple cleaning stations throughout your plant, simultaneously.

What really makes the Central Cleaning System special is the Heliopac[™] (Pressure-Amplifier-Condenser).

The Heliopac[™]

After extensive research and experimentation, inventor Carl Nicodemus discovered a phenomenon that allowed him to combine low pressure liquid with vapor, and discharge a high pressure liquid at levels never before attainable through a device with no moving parts. He continued to work on this discovery and the "Pressure - Amplifier - Condenser" (PAC or Heliopac) was born.

As steam enters the Heliopac, it is expanded to supersonic velocity and immediately condenses into an oncoming cold water stream. The steam's heat and momentum are transferred to the water thus producing an instantaneous supply of pressurized hot water. Because all the energy of the incoming vapor is used to heat and pressurize the incoming liquid, the Heliopac is nearly 100% efficient. For example: when using 125 psi steam pressure and a cold water supply of 60 psi, the Heliopac can deliver hot water at 300 psi and 185°F. The Heliopac does all this with no moving parts, making it the most efficient, low maintenance, hot water pump system available. The Heliopac replaces old style (conventional) systems that incorporate high pressure mechanical pumps and sparger, 'shell and tube', or plate type heat exchangers.

The Central Cleaning System[™]

Pressurized water is piped from the pressure reserve tank to desired cleaning locations within your plant. As this water is used, pressure within the reserve tank drops.

The Heliopac automatically starts and fills the reserve tank to the desired pressure, as set by the pressure switch. When the pre-set pressure is reached, the pressure switch opens and the system is in stand-by mode, waiting to be used.

Visit us on the World Wide Web
heliopac.com

Four Great Models

The HelioJET® Central Cleaning System™ supplies pressurized hot water to multiple cleaning stations throughout your plant simultaneously. Ideally, the system is placed in a central, out of the way location; such as a boiler or utility room. The high pressure hot water is then piped from the reserve tank to various locations throughout your plant where it can be used to supply all types of spray equipment such as spray guns, foamers, conveyor showers, tank wash machines, etc. HelioJET will recommend a complete C-System package including all accessories, tailored to meet your cleaning requirements.

Models are selected based on discharge flow requirements. For example; the model C-60 can deliver a maximum flow capacity of 60 gpm. The C-60 can be connected to an unlimited number of spray devices within your plant, and can supply any combination of them provided total water usage does not exceed 60 gpm.



Model C-15

Maximum flow capacity for the C-15 is 15 GPM. This model can supply up to three HelioJET G-7 Spray Guns (5 gpm each) simultaneously.



Model C-30

Maximum flow capacity for the C-30 is 40 GPM. This model can supply up to eight HelioJET G-7 Spray Guns (5 gpm each) simultaneously.



Model C-60

Maximum flow capacity for the C-60 is 60 GPM. This model can supply up to twelve HelioJET G-7 Spray Guns (5 gpm each) simultaneously.



Model C-100

Maximum flow capacity for the C-100 is 100 GPM. This model can supply up to twenty HelioJET G-7 Spray Guns (5 gpm each) simultaneously.

• Maximum flow capacity may vary depending on in-plant steam pressure.

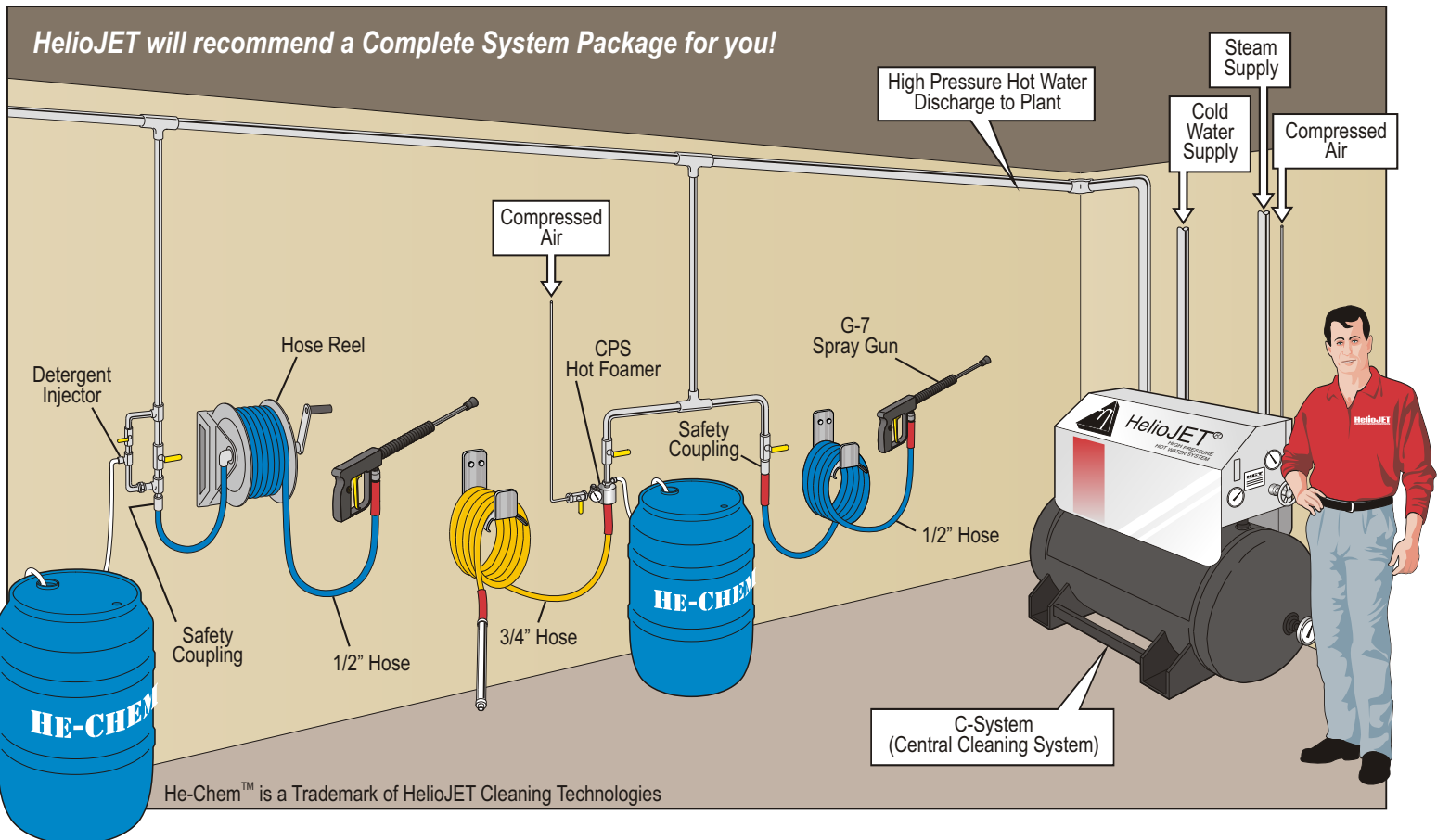

ACCESSORIES



G-7 Spray Gun (up to 8 GPM)

The G-7 Gun is the most popular choice for use with the Central Cleaning System™. It is rated for 600 PSI and 200°F, and can spray hot water up to 15 ft. with high impact. The G-7 has a 1/2" NPT hose connection, and is supplied with a 20" insulated spray barrel, one 0°, and one 15° fan pattern spray nozzle. When used with the Central Cleaning System, it is typically set up to deliver 5 GPM.



S-50 Spray Gun (8-15 GPM)

The S-50 Gun is rated for 600 PSI and 200°F, and can spray water up to 25 ft. with high impact. It has a 3/4" NPT hose connection, and is supplied with a 26" insulated spray barrel, one 0°, and one 15° fan pattern spray nozzle. When used with the Central Cleaning System, it is typically set up to deliver 10 GPM. The S-50 is only recommended for large open areas, low traffic areas, and in cases where a greater spray distance is required.



CPS Hot Foamer

The CPS Hot Foamer is installed out on the plant floor as part of the cleaning station used by sanitation personnel. It is normally installed on the same pipe drop as the HelioJET® G-7 or S-50 Spray Gun. The CPS Foamer requires high pressure hot water from your C-System, air from your shop compressor, and He-Chem™ Foaming Chemical Cleaners. During operation, He-Chem Foam Cleaners are automatically siphoned at up to 25% concentration. The CPS Foamer delivers a rich hot foam that can project up to 25 ft. After foam is applied, wait a few seconds and then rinse using the G-7 or S-50 spray gun.



Detergent Injectors

Detergent Injectors allow you to apply liquid hot water/detergent solution at up to 25% concentration. You can then rinse clean using high pressure hot water from the G-7 or S-50 Spray Gun.



Hose Reels

Standard Hose Reels are designed for 1/2" and 3/4" ID hose, can handle lengths of up to 100 ft., and are equipped with a hand crank rewind. All reels can be wall or floor mounted. They are constructed of steel and painted with a baked on enamel finish. Hose Reel options include: stainless steel construction, spring loaded rewind, motorized rewind. They can also be special ordered to accommodate hose lengths of up to 150 ft.



Fast Clean Showers™

Fast Clean Shower headers are customized to meet the requirements of your cleaning application, and are designed with internal rotating brushes that make it easy to clear spray nozzles when they become plugged.



He-Chem™ Proprietary Formulations

HelioJET will provide a He-Chem product specially suited to meet your cleaning requirements. We carry a full line of general purpose cleaners, degreasers, foam products, chlorinated cleaners, and lubricants. Contact us for a recommendation.

C-15



C-30



C-60



C-100



Performance Data

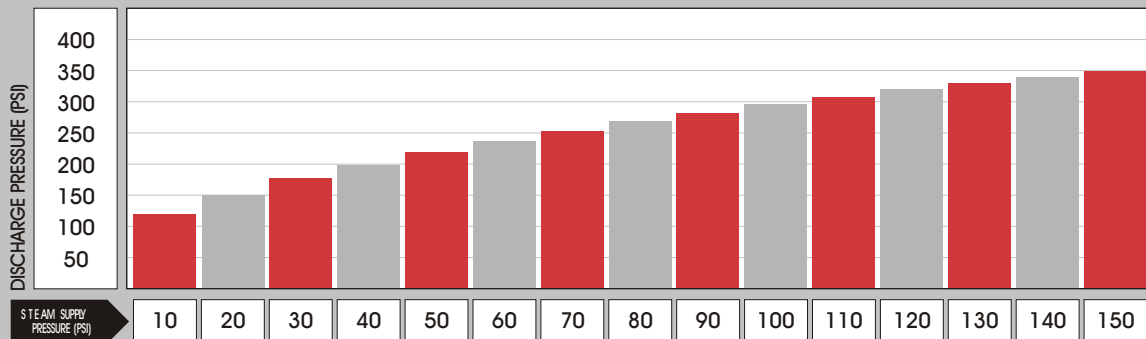

The above represents typical performance data. Output pressure may vary depending on water supply temperature and pressure.



888-223-5882
www.heliojet.com