

HelioPAC 60

Installation – Operation – Maintenance

HelioPAC (Pressure-Amplifier-Condenser)

Installation - Operation - Maintenance

The HelioPAC is a thermodynamic pump that generates remarkably high pressure hot water, using ordinary in-plant steam and cold water supplies.

SAFETY FIRST!

Be sure the following instructions are thoroughly understood before operating the HelioPAC. Direct any inquiries to HelioJET Cleaning Technologies, Inc. at **1-800-444-3546**.

! CAUTION !

This equipment can deliver:

1. A high pressure fluid which can penetrate the skin and cause severe internal injury!
2. A hot fluid which can severely burn the body.
3. A chemical solution ranging from mild to highly dangerous.

Therefore:

1. **ALWAYS** use hardware (valves, fittings, etc.) that are rated for the maximum discharge pressure and temperature at which you could be operating.
2. **NEVER** clean, change or remove nozzles without first turning off and locking out steam and water supplies.
3. **NEVER** exceed inlet pressures of 250 psi for either steam or water pressure.
4. **NEVER** operate the system with defective or leaky hoses or fittings.

-
- ▶ The HelioPAC is a powerful pressure amplifier which can multiply inlet pressures many times! For example: beginning with 150 psig of inlet water and steam, the discharge pressure could reach 800 psig at 212°F and be imbued with dangerous chemicals. The HelioPAC deserves respect.
 - ▶ Install in accordance with all applicable codes. Overflow shall be rigid pipe. Adequately support all equipment and plumbing.
 - ▶ Be sure condensate is removed from the steam supply before operation is attempted.
-

Installation Instructions:

- ▶ Install the HelioPAC in accordance with the installation drawing (Fig. 1) of this manual. Note that the HelioPAC unit is always mounted in a vertical position. Failure to mount properly will result in poor operating performance.
- ▶ Use steam and cold water connections as specified on the HelioPAC installation diagram (Fig. 1). Never undersize supply lines. If long lengths of pipe are required, increase diameters to avoid restrictions that can cause pressure drops.
- ▶ Always insulate steam lines. Always install a steam trap in the steam supply line to be sure condensate is removed before attempting to operate the HelioPAC.
- ▶ Overflow pipe shall be rigid and firmly anchored and piped directly into drain of larger diameter. Be sure personnel are safe from overflow splash. Never submerge overflow pipe under water. Never route overflow line upward or overhead.

Fig.1

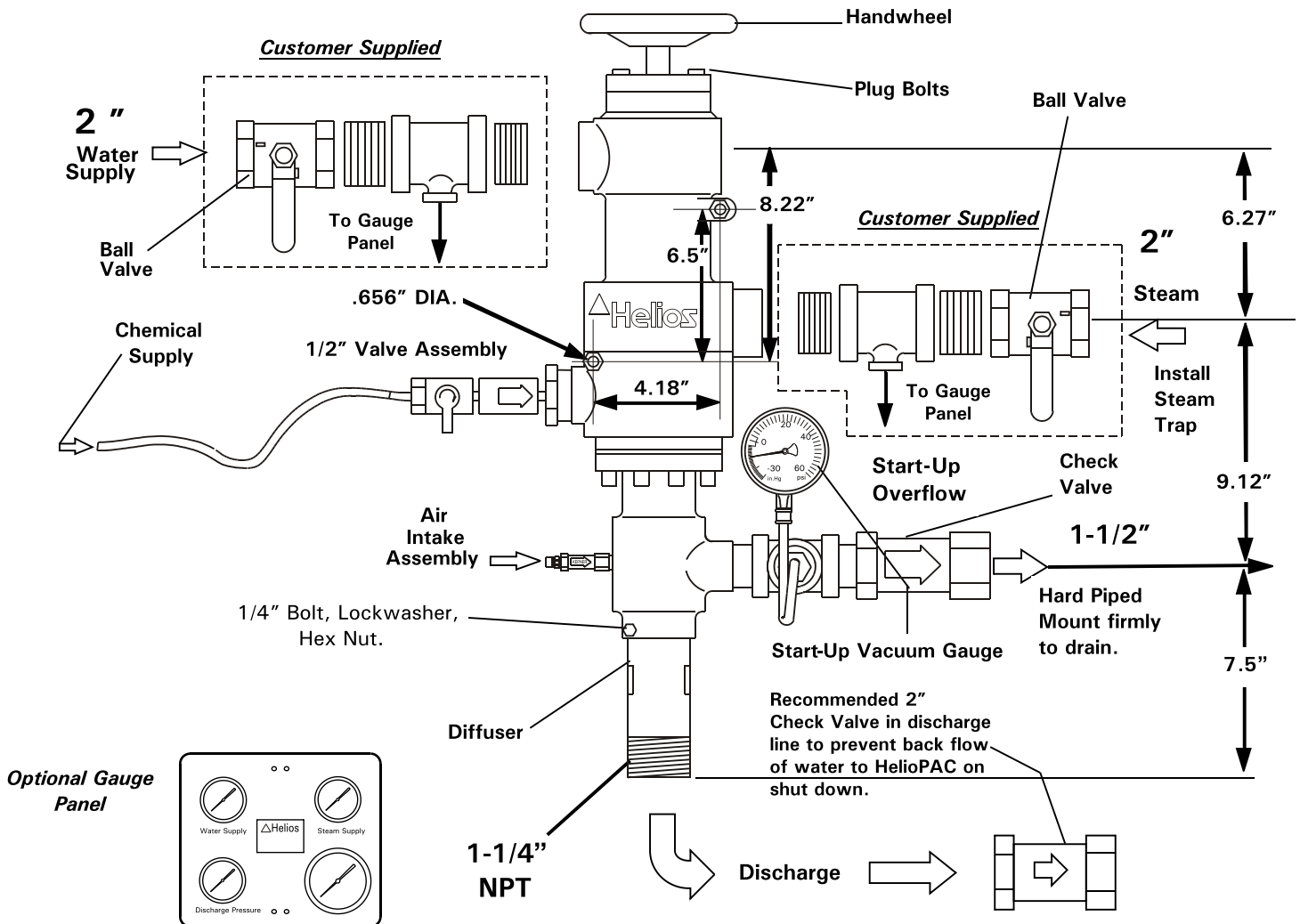

⚠ CAUTION ⚠

The HelioPAC **MUST** be installed strictly in accordance with the installation requirements of Fig. 1. Follow **ALL** local codes.

⚠ CAUTION ⚠

Start-up/over drain must be rigid pipe and firmly anchored. Overflow is **HOT**--use metal pipe and insulate for safety. Overflow must be piped to a safe location--be sure personnel are safe from overflow splash! Never pipe overflow overhead or submerge under water.

NOTE: Plugged internal orifices and/or spray nozzles will prevent start-up and require that the unit be dismantled for cleaning. In order to remove debris that is typically present in new piping installations, the water and steam supply lines must be thoroughly flushed before connecting the HelioPAC.

Initial Calibration and Start-up

1. Be sure all condensate has been purged from the steam supply line before attempting to start the HelioPAC.
2. Turn adjusting Handwheel (Fig.2) clockwise until it reaches the fully bottomed position.
3. Open necessary valves in order to allow water to flow to the spray apparatus (shower headers, tank washers, etc.).
4. Open cold water supply fully. Water will flow from the Start-up/overflow drain line.

Never Open Steam Supply First

5. Slowly open steam supply valve to the full open position.
6. Turn adjusting Handwheel counter-clockwise until water ceases to discharge from the Start-up/overflow drain. When overflow ceases, the HelioPAC is running. To complete the adjustment, continue to raise the Handwheel until vacuum gauge (Fig.2) reads 8" - 10".

NOTE: If you adjust the Handwheel too high, gauge will read less than 8" and steam vapor may eventually discharge from the Start-up/overflow drain. Adjust only as directed in step 6.

7. To turn off the HelioPAC, see "Shut Down Procedure" (following page).

Important Notes:

- Do not attempt to use the Handwheel as a temperature or pressure adjustment. It is not for the purpose of obtaining various operating temperatures or pressures.
- The Handwheel is a one time adjustment that provides a correct water to steam ratio within the HelioPAC.
- The Handwheel is only to be used as directed for initial start-up purposes.

Routine Start-up and Shutdown

After the initial Handwheel calibration is complete, operate the HelioPAC using the following procedure. The Handwheel should not require any further adjustment if the initial calibration procedure was done properly and there are no significant changes in the water or steam supply conditions.

Routine Start-up Procedure:

1. Fully open the water supply valve to the HelioPAC. Water will flow to drain from the Start-up/overflow.
2. Open steam valve **slowly**, bleed off any condensate that may be in the line. Fully open the steam supply valve. Water flowing to the Start-up/overflow drain will cease. When this occurs, the HelioPAC is running.
3. Open the Detergent Valve (if applicable).
4. To rinse, close the Detergent Valve.
5. To turn the unit off, see "Shut Down Procedure" below.

Shutdown Procedure:

1. Close Detergent Valve if open.
2. Close Steam Supply Valve.
3. Close Water Supply Valve.

CAUTION: Do not close the water valve before closing the steam valve. Live steam will discharge from the Start-up/overflow drain and Spray Apparatus.

Fig.2

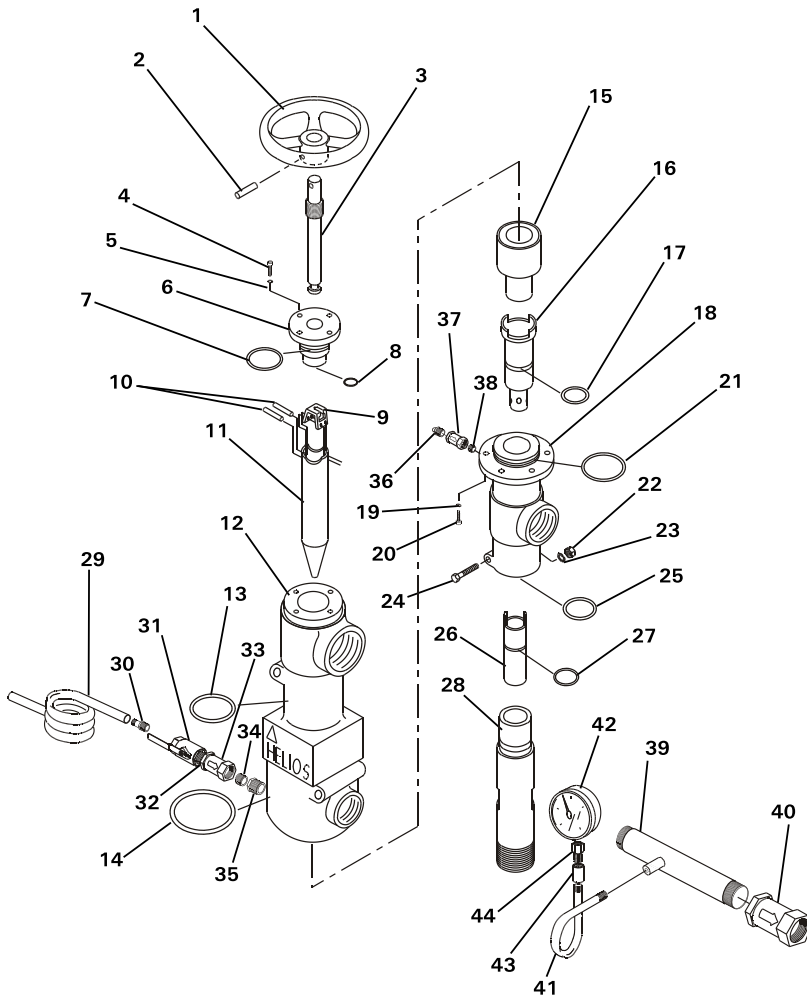

Item #	Component	(Part Number)
1.	Handwheel	2000189-(625)
2.	Dowel Pin (Handwheel)	615008
3.	Waterjet Shaft	100172
4.	Socket Headscrew (4)	612023
5.	Lockwasher (4)	613001
6.	Plug	200373
7.	O-Ring	611033
8.	O-Ring	611037
9.	Water Jet Bracket	100171
10.	Dowel Pins (Jet)	615021
11.	Waterjet	200348-(XXX)
12.	Body Casting	400032
13.	O-Ring	611032
14.	O-Ring	611010
15.	Mixing Chamber	200349-(XXX)
16.	* Amplifier	200350
17.	Oring (Amplifier)	611019
18.	Manifold	300057
19.	Lockwasher (6)	613001
20.	Socket Headscrew (6)	612023
21.	O-Ring	611011
22.	Nut (Shoulder)	614011
23.	Lockwasher (Shoulder)	613008
24.	Bolt (Shoulder)	612029
25.	O-Ring	611025
26.	* Insert	200351-(XXX)
27.	O-Ring	611006
28.	Diffuser	200352
Detergent Inlet Assembly (complete)		
29.	Vinyl Tubing	632055
30.	Hose Barb	632092
31.	Ball Valve	BV-1/2-02
32.	Nipple	616107
33.	Check Valve	CV-1/2-05
34.	Nipple	616107
35.	Bushing	625035
Start-up/overflow Assembly (complete)		
36.	Nozzle	100054-0020
37.	* Check Valve	CV-1/4-03
38.	Nipple	616054
39.	Nipple	616227
40.	* Check Valve	CV-1-1/2-04
41.	Pig Tail	630004
42.	* Vacuum Gauge	620030
43.	Coupling	622004
44.	Snubber	620032

* O-Ring Kit (complete) S-100054

* Recommended spare parts

HelioPAC™ Maintenance

After a long period of operation, wear will begin to occur at the smallest orifice diameters located in the Amplifier (#16) and Insert (#26). These two components will eventually need replacement. Indications of wear are a decrease in output pressure, and constant overflow, even after attempts have been made to adjust the handwheel. To confirm that wear has actually occurred, please consult our Technical Service Department before replacing these components: 1-585-768-8710.